

MODEL 10

# RAINER EFFLUENT APPLICATOR



**A very efficient, low cost, low pressure Travelling Effluent Irrigator.**

Big features, small machines

- ▶ Fully Hot Dipped Galvanised
- ▶ Simple to Operate
- ▶ Trouble Free Rotating Drive
- ▶ Variable Travel Speeds
- ▶ Low Pressure Operation
- ▶ Also Suitable for Irrigation
- ▶ Operates with Lay Flat and Hard Hoses
- ▶ Low Running Costs
- ▶ Heavy Duty Wire Rope
- ▶ Automatic Wire Rope Layering
- ▶ Application Rate as low as 5mm

**OPTIONAL EXTRA:**

Automatic Cut Off

IMPORTERS AND DISTRIBUTORS OF ZIMMATIC PIVOTS

MANUFACTURED IN **NEW ZEALAND**  
BY RAINER IRRIGATION LIMITED



# MODEL 10 EFFLUENT IRRIGATOR



## SPECIFICATIONS

Operating Pressure	100-200 KPA. (15-30 psi)
Run Length	Up to 200 m
Wetted Width	Up to 25 m
Run Width	20 m
Run Time	Variable to Suit
Flow Range	2 to 5.5 l/s
Boom Height	1.1 m
Boom Length	7 m
Wheel Track	1.55 m
Crop Clearance	0.45 m

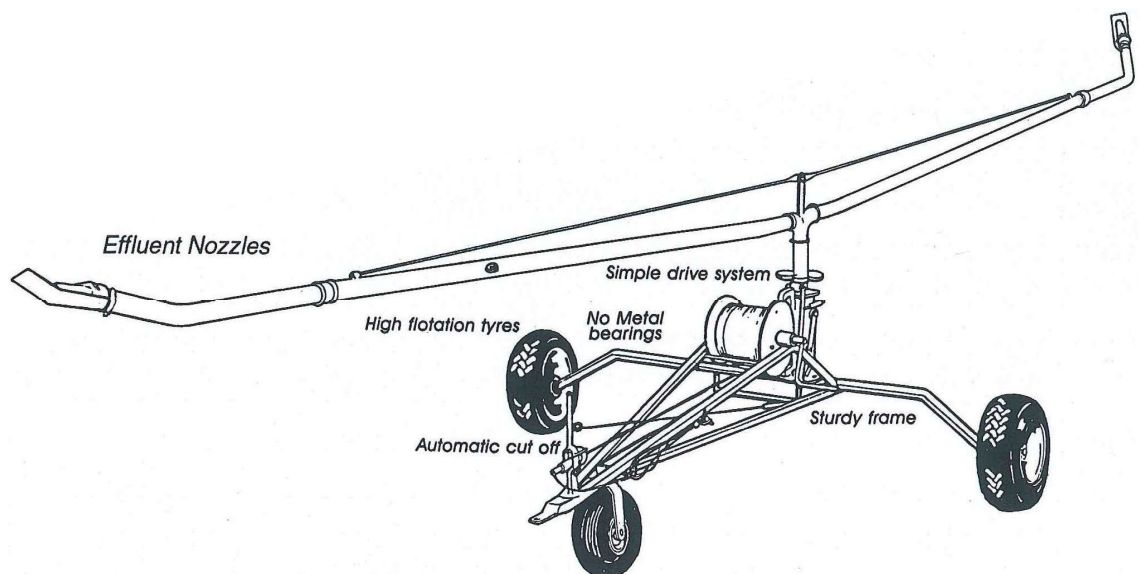

DISTRIBUTOR:

MANUFACTURED IN NEW ZEALAND BY RAINER IRRIGATION LIMITED

**Call 03 307 9049**

Cnr Robinson & McNally Streets, Ashburton • Phone 03 307 9049  
Email [admin@ashburton.co.nz](mailto:admin@ashburton.co.nz) • [www.rainer.co.nz](http://www.rainer.co.nz)

